

sofamel

Product Technical Specifications

ECBT-MPUE

Earthing and short-circuit equipment
– Low voltage electric panels

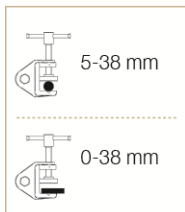
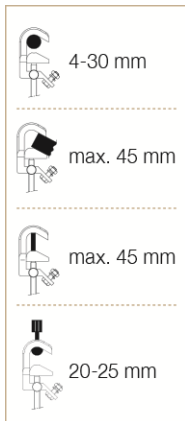
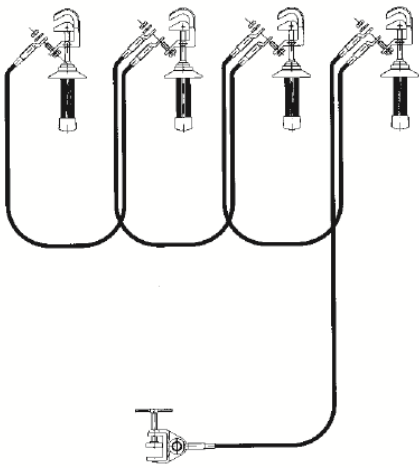

Functionality

Earthing and short-circuit kit for low-voltage distribution boards. The main reason for their installation is to protect the worker from accidental power-on or return of voltage during repair work.



ECBT-MPUE

Equipos de puesta a tierra y cortocircuito - Cuadros eléctricos de Baja tensión

Ref.	Short circuit current Max. ICC
ECBT-MPUE/35	9 KA / 1S

Product Features

The MPUE clamps can be fixed on uncovered cylindrical conductors, plates, bending bars (distribution) or fixing points. Each one has its own fixed grip.

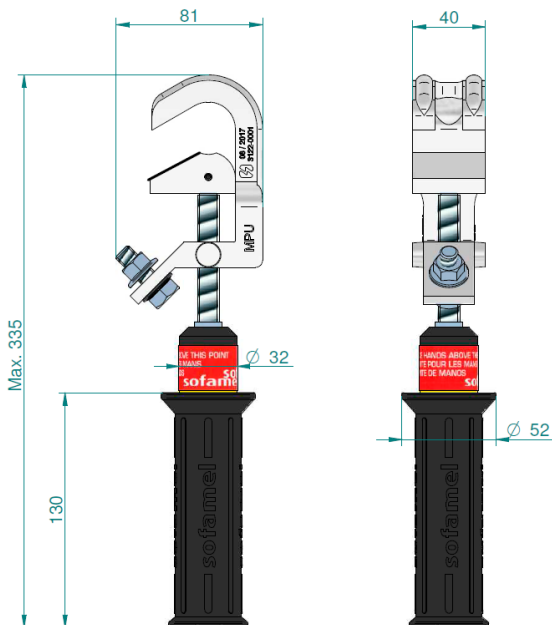

Composed of

- 4 MPUE aluminium alloy clamps with screw tighten and insulated grip for cylindrical conductors with diameter between 4 and 30 mm, flat bars max. 45 mm, bending bus-bars max. 45 mm and fixing points between \varnothing 20 and 25 mm.
- 3 copper cables with PVC insulation of 35 mm² section and 0,6 m long.
- 1 copper cable with PVC insulation of 25 mm² section and 2 m long.
- 1 TT-38A milling earthing lathe.
- 1 plastic case to store and transport the equipment.

Certified

For the manufacture of this equipment is taken as a reference Standard **UNE-EN 61230**.



MPUE



TT-38A

Datos sujetos a cambios
2022, Mayo 5

© 2017 Sofamel SLU
Todos los derechos reservados.

Versión: R2-7.2 COM01

Las especificaciones están sujetas a cambios sin previo aviso.