

10301 MAL

Manguito de aluminio tubular DIN

Los manguitos MAL están fabricados en tubo de aluminio de pureza igual o superior al 99,5%. Incorporan un tope central que divide el conector en dos partes iguales. Se incorpora grasa neutra en el interior para evitar la oxidación del aluminio.

Conforme a la norma DIN 46267.

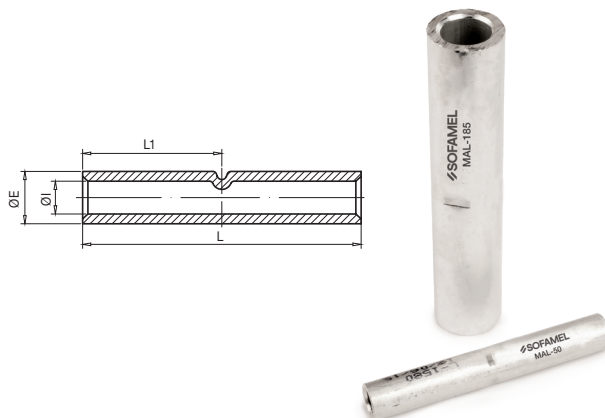

Código	Ref.	Sección (mm ²)	Dimensiones (mm)				Kg x 100	Bolsa	Caja
			ØE	ØI	L	L1			
080100	MAL-25	25	12,0	6,8	70,0	35,0	1,880	1	250
080110	MAL-35	35	14,0	8,2	85,0	42,5	2,660	1	200
080120	MAL-50	50	16,0	9,8	85,0	42,5	2,840	1	200
080130	MAL-70	70	18,5	11,2	105,0	52,5	3,700	1	100
080140	MAL-95	95	22,0	13,2	105,0	52,5	4,700	1	100
080150	MAL-120	120	23,0	14,7	105,0	52,5	9,200	1	90
080160	MAL-150	150	25,0	16,5	125,0	62,5	12,300	1	60
080170	MAL-185	185	28,5	18,5	125,0	62,5	13,800	1	60
080180	MAL-240	240	32,0	21,3	145,0	72,5	18,800	1	50
080190	MAL-300	300	34,0	23,6	145,0	72,5	25,000	1	50