

Cosses et Manchons à Vis Fusibles

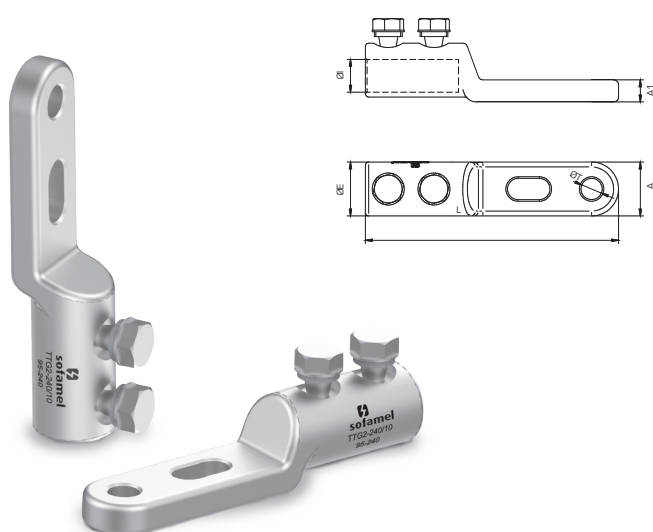





CONNEXIÓN CATALOGUE



102 TTG2

Cosse à vis fusible

Les cosses TTG/2 sont fabriquées en alliage d'aluminium haute conductivité, d'une pureté égale ou supérieure à 99,5 %; la finition superficielle étamée couvre toute la surface de la cosse grâce à un bain électrolytique.

Code	Réf.	Section (mm ²)	 Long. déganage	 2 x M17	 17	Dimensions (mm)						 x 100	 Sac	 Boîte	
						ØE	ØI	L	ØT	A	A1				
101180	TTG/2-240/10	95 a 240	2	60	2 x M17	17	33	20	155	11	33	13,5	22,300	1	-
101185	TTG/2-240/12						33	20	155	13	33	13,5	21,700	1	-