

Dispositivi di messa a terra / Accessori per attrezzature

30911 Morsetti di bassa tensione

MPUE

Codice 671112

Dimensioni: 335 x 81 x 52 mm

Peso: 0,6 kg

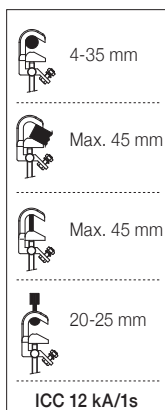

MPUL

Codice 671113

Dimensioni: 335 x 81 x 52 mm

Peso: 1,2 kg

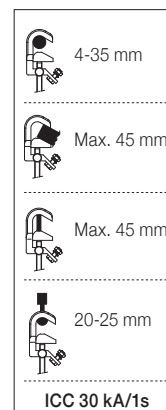

PEBT

Codice 658115

Dimensioni: 815 x 58 x 40 mm

Peso: 0,35 kg

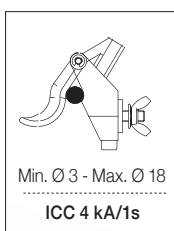

MPUBT

Codice 659001P

Dimensioni: 160 x 82 x 40 mm

Peso: 0,36 kg

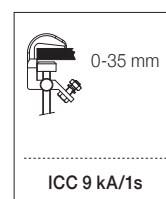

Dispositivi di messa a terra / Accessori per attrezzature

30911 Pinze di media tensione

MPUH

Codice 671110

Dimensioni: 202 x 81 x 40 mm
Peso: 0,48 kg



MPUH-L

Codice 671117

Dimensioni: 202 x 81 x 40 mm
Peso: 1,16 kg



MPUB

Codice 671115

Dimensioni: 240 x 81 x 40 mm
Peso: 0,53 kg

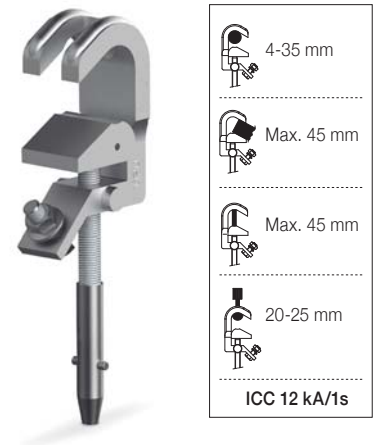

MPUB-L

Codice 671118

Dimensioni: 240 x 81 x 40 mm
Peso: 1,65 kg

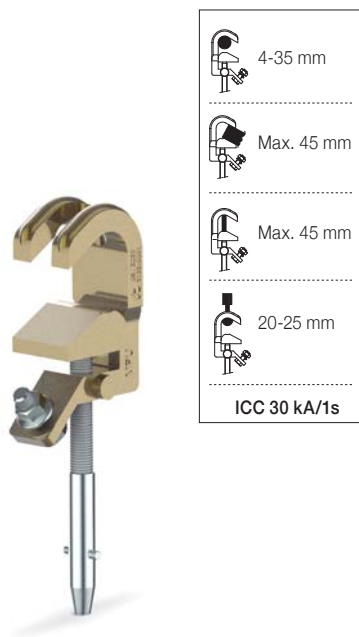

PC

Codice 666005

Dimensioni: 440 x 157 x 54 mm
Peso: 1,3 kg



MPUP

Codice 671116

Dimensioni: 240 x 81 x 156 mm
Peso: 0,7 kg



Dispositivi di messa a terra / Accessori per attrezzature

30911 Pinze di media tensione

MPUP-L

Codice 671119

Dimensioni: 240 x 81 x 156 mm
Peso: 1,34 kg

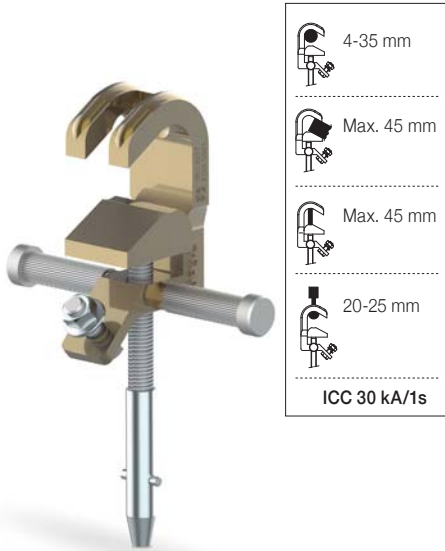

PDC

Codice 666010

Dimensioni: 413 x 105 x 52 mm
Peso: 0,85 kg

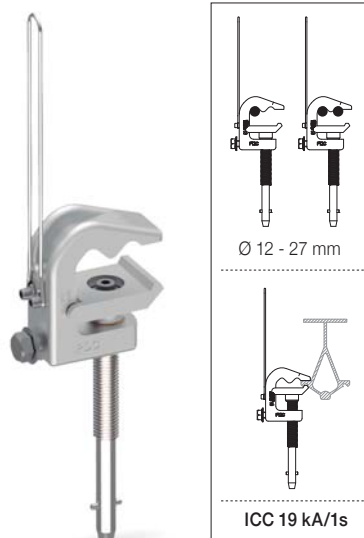

MCL

Codice 671121

Dimensioni: 182 x 128 x 68 mm
Peso: 0,67 kg



5014H

Codice 671100

Dimensioni: 167 x 91 x 83 mm
Peso: 0,8 kg

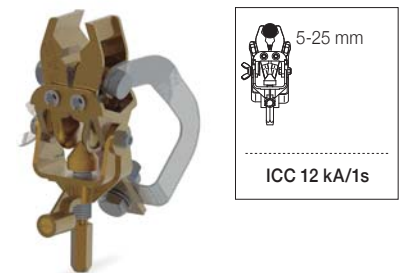

MC

Codice 671120

Dimensioni: 226 x 102 x 62 mm
Peso: 0,4 kg



PCA-25

Codice 671171

Dimensioni: 276 x 123 x 74 mm
Peso: 0,81 kg



PP15

Codice 671166

Dimensioni: 241 x 95 x 47 mm
Peso: 0,68 kg



Dispositivi di messa a terra / Accessori per attrezzature

30911 Pinze di alta tensione

MPL

Codice 671172

Dimensioni: 263 x 105 x 62 mm
Peso: 0,97 kg

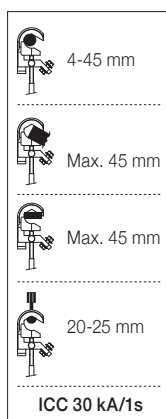

MPLE

Codice 671178

Dimensioni: 263 x 110 x 62 mm
Peso: 1 kg

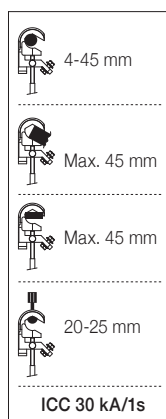

MPLP

Codice 671173

Dimensioni: 263 x 105 x 204 mm
Peso: 1,1 kg

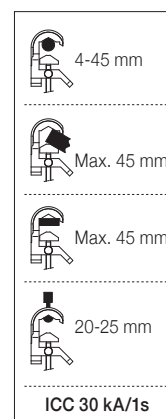

PAV-48

Codice 673100

Dimensioni: 380 x 170 x 120 mm
Peso: 1,6 kg

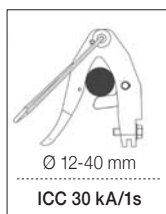

TML

Codice 670100P

Dimensioni: 428 x 133 x 53 mm
Peso: 1,56 kg

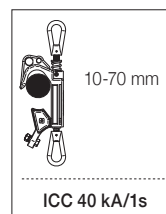

TMC

Codice 675100P

Dimensioni: 273 x 248 x 45 mm
Peso: 1,18 kg

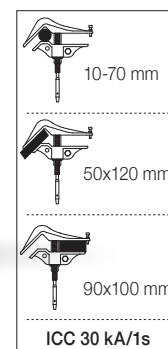

Dispositivi di messa a terra / Accessori per attrezzature

30911 Pinze di alta tensione

PA40A

Codice 674100 – Baionetta
Codice 674102 – Esagonale

Dimensioni: 331 x 206 x 80 mm
Peso: 1,7 kg

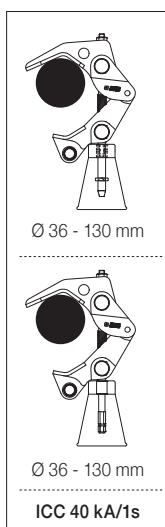

PA40ABP

Codice 674105 - Esagonale H22

Dimensioni: 341 x 206 x 80 mm
Peso: 1,6 kg

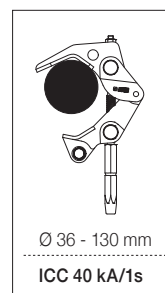

30911 Manopole per bassa tensione

EMB

Codice 671106

Dimensioni: 198 x Ø 52 mm
Peso: 0,3 kg



EMP

Codice 659001E

Dimensioni: 218 x Ø 52 mm
Peso: 0,25 kg



30911 Morsetto di scarico potenziale

BPGA

Codice 672205

Dimensioni: 3262 x 141 x 298 mm
Peso: 7,8 kg

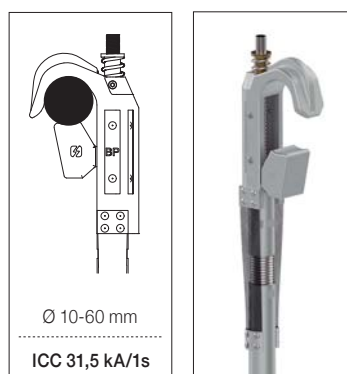

Dispositivi di messa a terra / Accessori per attrezzature

30911 Morse di messa a terra

TT-38A

Codice 671141

Dimensioni: 158 x 92 x 35 mm
Peso: 0,48 kg

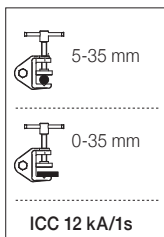

TT-38L

Codice 671145

Dimensioni: 158 x 92 x 35 mm
Peso: 0,93 kg

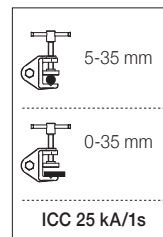

TT-50

Codice 671152

Dimensioni: 250 x 147 x 40 mm
Peso: 0,95 kg

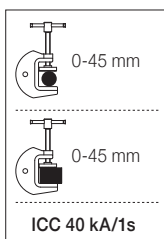

TTSR

Codice 666015

Dimensioni: 280 x 214 x 55 mm
Peso: 3,45 kg

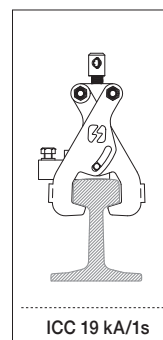

TTR

Codice 671153

Dimensioni: 115 x 117 x 60 mm
Peso: 1,1 kg

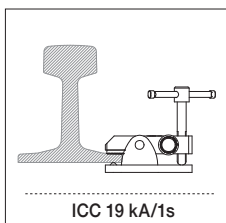

TTIR

Codice 671154

Dimensioni:
54 x 65 x 50 mm
Peso: 0,95 kg

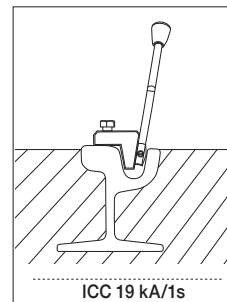

Dispositivi di messa a terra / Accessori per attrezzature

30911 Morsetto antivandalo

TTR-AN

Codice 30911000

Dimensioni: 115 x 117 x 60 mm

Peso: 1,1 kg

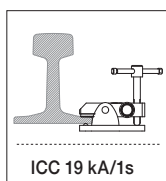

Il morsetto antivandalo TTR-AN è stato appositamente progettato per apparecchiature portatili di messa a terra, fornendo un fissaggio sicuro in ambienti esposti al pubblico o dove esiste il rischio di manomissioni non autorizzate.

Il suo design incorpora un perno estraibile, che l'operatore inserisce durante l'installazione e successivamente rimuove e conserva. Una volta rimosso il perno, il morsetto non può essere aperto né smontato, impedendo a terzi di manomettere il collegamento di messa a terra.

Realizzato con materiali ad alta resistenza e un sistema di serraggio robusto, il TTR-AN garantisce un utilizzo affidabile, sicuro e duraturo nelle operazioni di manutenzione, riparazione e manovra.

30911 Morse di messa a terra

PEP

MORSETTO EQUIPOTENZIALE PER PALO

Codice P-671180

Dimensioni: 420 x 202 x 70 mm

Peso: 4,5 kg



Max. Ø 400 mm



Min. Ø 90 mm



PEP-ECO

MORSETTO EQUIPOTENZIALE PER PALO

Codice P-671185

Dimensioni: 325 x 200 x 60 mm

Peso: 3,7 kg



Max. Ø 400 mm



Min. Ø 90 mm



Dispositivi di messa a terra / Accessori per attrezzature
30911 Piattelli portapinzze articolati

I piattelli portapinzze PPA sono stati progettati per migliorare l'ergonomia e la rapidità nell'installazione delle apparecchiature di messa a terra. A differenza dei modelli standard, questi piattelli incorporano bracci articolati che permettono di orientare singolarmente ogni pinza, adattandosi meglio alla geometria del supporto o del punto di collegamento.

Questa articolazione garantisce un posizionamento più comodo, rapido e preciso, riducendo i tempi di manovra dell'operatore e facilitando il montaggio anche in configurazioni complesse o in spazi ridotti.

PPA-3

Codice 30911005

PPA-4

Codice 30911006

PPA-3U

Codice 30911007

PPA-4U

Codice 30911008

30911 Piattelli portapinzze
PP-3

Codice 671126

PP-4

Codice 671127

PP-3U

Codice 671128

PP-4U

Codice 671129

PP-3 MCL

Codice 671131

PP-4 MCL

Codice 671132

PP-3U MCL

Codice 671122

PP-4U MCL

Codice 671123

PP-1U MCL

Codice 630168



Dispositivi di messa a terra / Accessori per attrezzature

30911 Valigia con ruote

SOFABOX

Codice 620061

Dimensioni: 855 x 577 x 400 mm

Ideale per trasportare le apparecchiature di messa a terra. Garantisce una mobilità facile e comoda, offrendo una soluzione affidabile per spostare in sicurezza l'attrezzatura nei diversi luoghi di lavoro.



Piede in acciaio pieghevole
Consente lo stoccaggio orizzontale della valigia.



Maniglie pieghevoli
La valigia ha maniglie nella parte superiore e laterale per facilitare il trasporto in ogni momento.



30911 Dispensori di messa a terra

Dispensore di messa a terra esagonale

Codice 667150

Dimensioni: 1 m
Peso: 2,150 kg

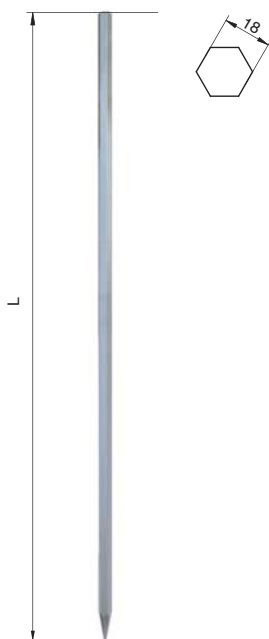

Dispensore di messa a terra elicoidale

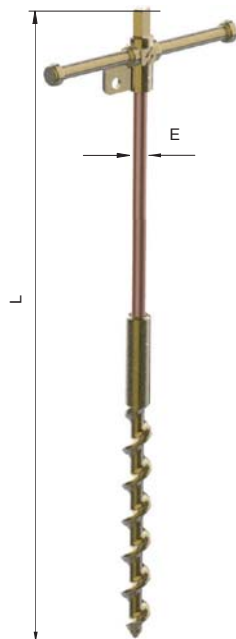

Codice	Rif.	L	ØE	kg
P-671190	PTB14-1000	1000		2,7
P-671191	PTB14-1300	1300	14,6	2,85
P-671192	PTB14-1500	1500		3
P-671193	PTB18-1000	1000		3,2
P-671194	PTB18-1300	1300	18,2	3,55
P-671195	PTB18-1500	1500		3,86

Dispositivi di messa a terra / Accessori per attrezzature

Punti fissi

Utilizzati nelle installazioni elettriche per collegare e fissare in modo sicuro i morsetti delle attrezzature PAT.

Secondo la norma DIN 48088 parte 1. - Materiale: Ottone stagnato di 20 micron e viti in acciaio inox.

30912 Punto fisso sfera dritto - Femmina

FILETTATURA INTERNA

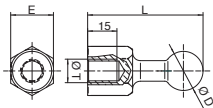

Codice	Rif.	ØD	ICC Max. kA/1s	E	L	ØT
P-665020	PFRH-20M12	20	12	SW22	59	M12
P-665022	PFRH-20M16					M16
P-665024	PFRH-20M12	25	25	SW27	69	M12
P-665026	PFRH-20M16					M16

30913 Punto fisso sfera dritto - Maschio

FILETTATURA ESTERNA

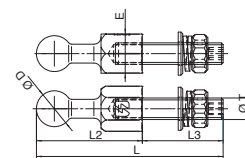

Codice	Rif.	ØD	ICC Max. kA/1s	E	L	L2	L3	ØT
P-665030	PFRM-20M12x35	20	12	SW22	94	59	35	M12
P-665032	PFRM-20M12x45						45	M12
P-665034	PFRM-20M16x35						35	M16
P-665036	PFRM-20M16x45						45	M16
P-665038	PFRM-25M12x35	25	25	SW27	114	69	35	M12
P-665040	PFRM-25M12x45						45	M12
P-665042	PFRM-25M16x35						35	M16
P-665044	PFRM-25M16x45						45	M16

30912 Punto fisso sfera 45° - Femmina

FILETTATURA INTERNA

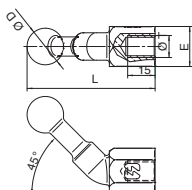

Codice	Rif.	ØD	ICC Max. kA/1s	E	L	ØT
P-665050	PF45H-20M12	20	12	SW22	70	M12
P-665052	PF45H-20M16					M16
P-665054	PF45H-25M12	25	25	SW27	82	M12
P-665056	PF45H-25M16					M16

30913 Punto fisso sfera 45° - Maschio

FILETTATURA ESTERNA

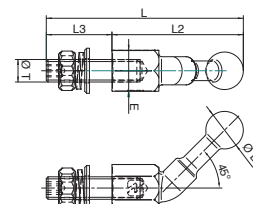

Codice	Rif.	ØD	ICC Max. kA/1s	E	L	L2	L3	ØT
P-665060	PF45M-20M12x35	20	12	SW22	105	70	35	M12
P-665062	PF45M-20M16x45						45	M16
P-665064	PF45M-25M12x45	25	25	SW27	127	82	45	M12
P-665066	PF45M-25M16x45						45	M16

30912 Punto fisso sfera 90° - Femmina

FILETTATURA INTERNA

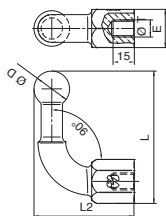

Codice	Rif.	ØD	ICC Max. kA/1s	E	L	L2	ØT
P-665070	PF90H-20M12	20	12	SW22	75	58	M12
P-665072	PF90H-20M16						M16
P-665074	PF90H-25M12	25	25	SW27	93	70	M12
P-665076	PF90H-25M16						M16

30913 Punto fisso sfera 90° - Maschio

FILETTATURA ESTERNA

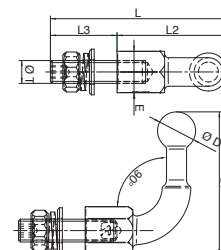

Codice	Rif.	ØD	ICC Max. kA/1s	E	L	L2	L3	ØT
P-665080	PF90M-20M12x35	20	12	SW22	93	58	35	M12
P-665082	PF90M-20M16x45						45	M16
P-665084	PF90M-25M12x45	25	25	SW27	115	70	45	M12
P-665086	PF90M-25M16x45						45	M16